

SCR Controllers

75 - 100AMP

1 Phase



PS, PSH, PSX, ZT, ZS Series

Clark Power Systems Inc.

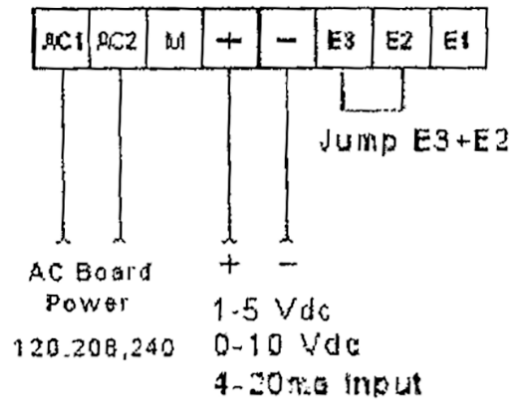
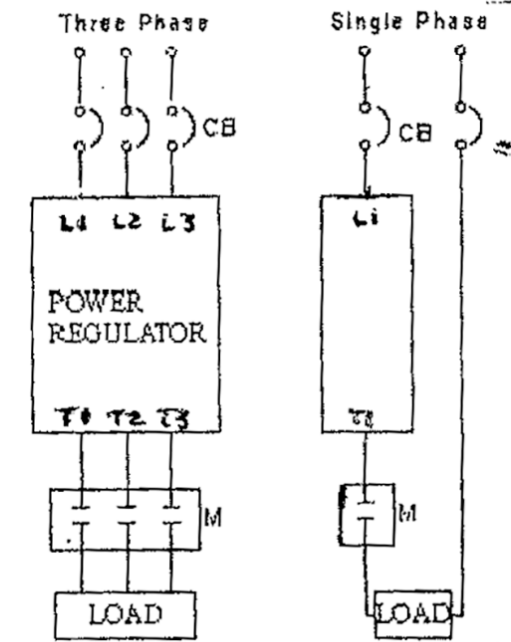

Connection Notes:

- 1) 4-20ma = 250 ohms
(unit has internal resistor built in)
- ** Board jumper position = P1 to S1
- 2) Manual Pot, 0-5Vdc = 30K ohm
- ** Board jumper position = P1 to S2
- 3) 2-10Vdc, 0-10Vdc = 12K ohms
- ** Board jumper position = P1 to S3

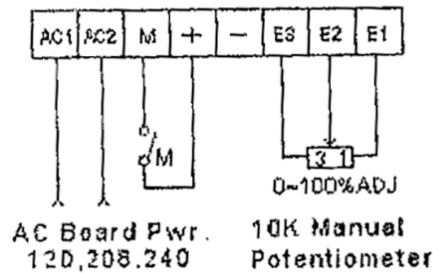

*For Line Run-Jump "M to +"
and remove the M Contactor

PSH Series

Single Phase, Phase Angle Control

Application- Variable Voltage Control of High Inrush Variable Resistive Loads

Call us today @ 203-775-8444

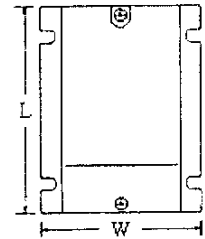

Model Number	Full Load Amps	KVA @ Max Rated Volts	Open Chassis Dimensions (In inches)			Price
			Length	Width	Depth	
120 Vac Input, 0-118 Vac Output, 50/60 Hz						
PSH-1-20	20	2.4	6.5	4	5.5	\$275
PSH-1-30	30	3.6	6.5	4	5.5	\$299
PSH-1-50	50	5.9	6.5	4	5.5	\$349
PSH-1-75	75	9	6.5	4.5	7.5	\$399
PSH-1-100	100	12	7.5	4.5	7.5	\$499
PSH-1-125	125	14	11	4.5	7.5	\$575
PSH-1-150	150	18	11	4.5	7.5	\$***
PSH-1-180	180	21.6	11	4.5	7.5	\$***
PSH-1-225	225	27	11.5	4.5	7.5	\$***
PSH-1-300	300	35	16	5.5	9.75	\$***
PSH-1-400	400	45	16	5.5	9.75	\$***
PSH-1-500	500	60	16	5.5	9.75	\$***
PSH-1-600	600	72	18	5.5	9.75	\$***
PSH-1-750	750	90	22	5.5	9.75	\$***
240 Vac Input, 0-238 Vac Output, 50/60 Hz (ALSO FOR 208/220/230 VAC INPUT)						
PSH-2-20	20	4.8	6.5	4	5.5	\$299
PSH-2-30	30	7.2	6.5	4	5.5	\$349
PSH-2-50	50	12	6.5	4	5.5	\$375
PSH-2-75	75	18	6.5	4.5	7.5	\$449
PSH-2-100	100	24	7.5	4.5	7.5	\$525
PSH-2-125	125	28	11	4.5	7.5	\$625
PSH-2-150	150	35	11	4.5	7.5	\$***
PSH-2-180	180	43.2	11	4.5	7.5	\$***
PSH-2-225	225	53	11.5	4.5	7.5	\$***
PSH-2-300	300	70	16	5.5	9.75	\$***
PSH-2-400	400	95	16	5.5	9.75	\$***
PSH-2-500	500	120	16	5.5	9.75	\$***
PSH-2-600	600	144	18	5.5	9.75	\$***
PSH-2-750	750	180	22	5.5	9.75	\$***
480 Vac Input, 0-478 Vac Output, 50/60 Hz (ALSO FOR 380/415/440VAC INPUT)						
PSH-4-20	20	9.6	6.5	4	5.5	\$325
PSH-4-30	30	14	6.5	4	5.5	\$375
PSH-4-50	50	23	6.5	4	5.5	\$399
PSH-4-75	75	35	6.5	4.5	7.5	\$499
PSH-4-100	100	47	7.5	4.5	7.5	\$579
PSH-4-125	125	60	11	4.5	7.5	\$649
PSH-4-150	150	70	11	4.5	7.5	\$***
PSH-4-180	180	86	11	4.5	7.5	\$***
PSH-4-225	225	105	11.5	4.5	7.5	\$***
PSH-4-300	300	140	16	5.5	9.75	\$***
PSH-4-400	400	190	16	5.5	9.75	\$***
PSH-4-500	500	240	16	5.5	9.75	\$***
PSH-4-600	600	285	18	5.5	9.75	\$***
PSH-4-750	750	360	22	5.5	9.75	\$***

*****600 Vac Input, 0-595 Vac Output, 50/60 Hz *(ALSO FOR 575/590/600VAC INPUT) Are Available !**

*** Call us for Current Pricing. Add Options to the above models: Zero Soft Start time & IL-Current Limit. Incoming Main Line L1 is fuse protected. All external required parts are customer provided. Non Standard units can be provided. We can build units from 24 to 1000Vac and up to 5,000 Amps. 1 Year Warranty on all standard units listed above. Controllers are only CE listed on some select models. See our web page warranty policy. Also provided are frequencies up to 400 Hz. All prices listed, ratings, dimensions and warranty policy can change without notice.