

SCR Controllers
125 - 180AMP
3 Phase

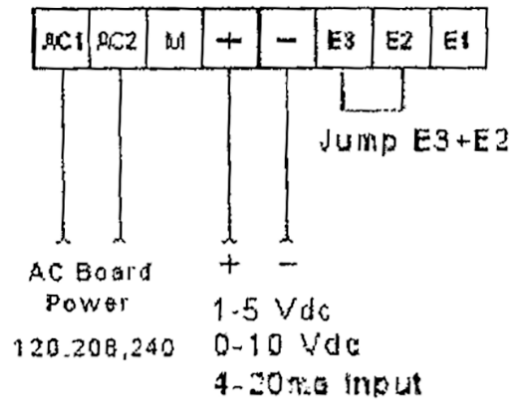

PT, PTH, PTX, ZZT Series
Clark Power Systems Inc.

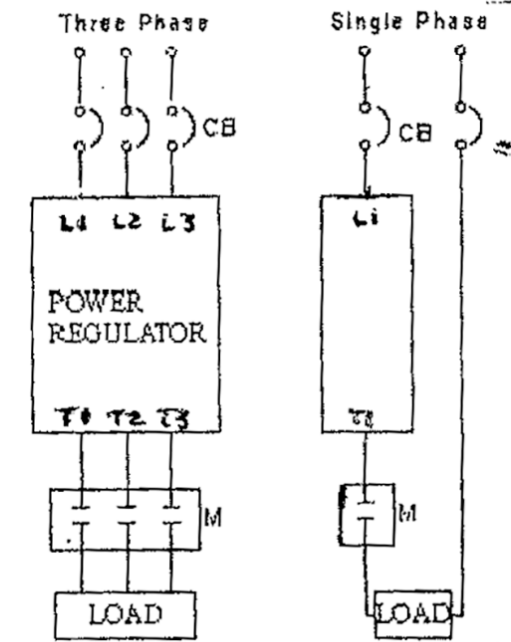

Connection Notes:

- 1) 4-20ma = 250 ohms
(unit has internal resistor built in)
- ** Board jumper position = P1 to S1
- 2) Manual Pot, 0-5Vdc = 30K ohm
- ** Board jumper position = P1 to S2
- 3) 2-10Vdc, 0-10Vdc = 12K ohms
- ** Board jumper position = P1 to S3

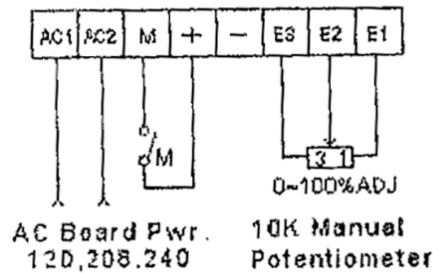

*For Line Run-Jump "M to +"
and remove the M Contactor

ZZT Series

Part Numbers, Standard Sizes, Prices and Dimensions:

Description- 3 Phase-3 Leg, Zero Fired Control

NOTE: this unit runs at near 100% power factor, Low Harmonics

Application-Time Proportioned Voltage Control of Constant Resistance Loads.

Call us today @ 203-775-8444

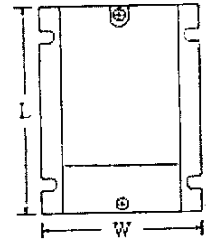

Model Number	Full Load Amps	KVA @ Max Rated Volts	Open Chassis Dimensions (In inches)			Price
			Length	Width	Depth	
*240 Vac Input, 0-238 Vac Output, 50/60 Hz *(ALSO FOR 208/220/230 VAC INPUT)						
ZZT-2-20	20	8	8.0	5.5	5.7	\$389
ZZT-2-30	30	12	8.0	5.5	5.7	\$449
ZZT-2-50	50	20	8.0	5.5	5.7	\$549
ZZT-2-75	75	30	8.0	5.5	8.0	\$629
ZZT-2-100	100	40	8.0	5.5	8.0	\$899
ZZT-2-125	125	50	13	5.5	8.0	\$1199
ZZT-2-150	150	60	13	5.5	8.0	\$***
ZZT-2-180	180	72	15	5.5	8.0	\$***
ZZT-2-225	225	92	13	8.5	11	\$***
ZZT-2-300	300	120	16	8.5	11	\$***
ZZT-2-400	400	160	16	8.5	11	\$***
ZZT-2-500	500	207	16	15	10	\$***
ZZT-2-600	600	250	18	15	10	\$***
ZZT-2-750	750	305	22	15	10	\$***
*480 Vac Input, 0-478 Vac Output, 50/60 Hz *(ALSO FOR 380/415/440VAC INPUT)						
ZZT-4-20	20	16	8.0	5.5	5.7	\$399
ZZT-4-30	30	24	8.0	5.5	5.7	\$499
ZZT-4-50	50	40	8.0	5.5	5.7	\$585
ZZT-4-75	75	60	8.0	5.5	8.0	\$679
ZZT-4-100	100	80	8.0	5.5	8.0	\$949
ZZT-4-125	125	100	13	5.5	8.0	\$1299
ZZT-4-150	150	120	13	5.5	8.0	\$***
ZZT-4-180	180	140	15	5.5	8.0	\$***
ZZT-4-225	225	180	13	8.5	11	\$***
ZZT-4-300	300	240	16	8.5	11	\$***
ZZT-4-400	400	310	16	8.5	11	\$***
ZZT-4-500	500	400	16	15	10	\$***
ZZT-4-600	600	480	18	15	10	\$***
ZZT-4-750	750	600	22	15	10	\$***
*600 Vac Input, 0-595 Vac Output, 50/60 Hz *(ALSO FOR 575/590/600VAC INPUT)						
ZZT-6-20	20	19	8.0	5.5	5.7	\$499
ZZT-6-30	30	28	8.0	5.5	5.7	\$599
ZZT-6-50	50	48	8.0	5.5	5.7	\$699
ZZT-6-75	75	73	8.0	5.5	8.0	\$899
ZZT-6-100	100	98	8.0	5.5	8.0	\$1199
ZZT-6-125	125	120	13	5.5	8.0	\$1499
ZZT-6-150	150	145	13	5.5	8.0	\$***
ZZT-6-180	180	180	15	5.5	8.0	\$***
ZZT-6-225	225	225	13	8.5	11	\$***
ZZT-6-300	300	300	16	8.5	11	\$***
ZZT-6-400	400	400	16	8.5	11	\$***
ZZT-6-500	500	510	16	15	10	\$***
ZZT-6-600	600	600	18	15	10	\$***
ZZT-6-750	750	745	22	15	10	\$***

***Call us for Current Pricing. Add Options to the above models: Zero Soft Start time (Standard is 2S). Incoming Main Line L1, L2 & L3 are fuse protected.

All external required parts are customer provided. Non Standard units can be provided. We can build units from 24 to 1000Vac and up to 5,000 Amps.

1 Year Warranty on all standard units listed above. Controllers are only CE listed on some select models. See our web page warranty policy

Also provided are frequencies up to 400 Hz. All prices listed, ratings, dimensions and warranty policy can change without notice.